

Modell Übersicht

Overview of Models

Lewens
MARKISEN

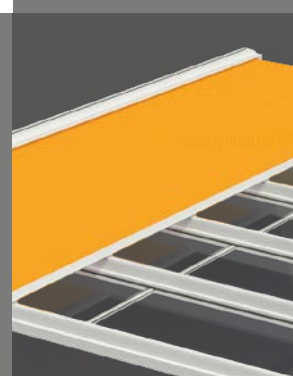

made
in
germany

CE EN 1090, EN 13561

Gelenkarmmarkise (Tragrohr)
Folding arm awning (back bar)

Economy

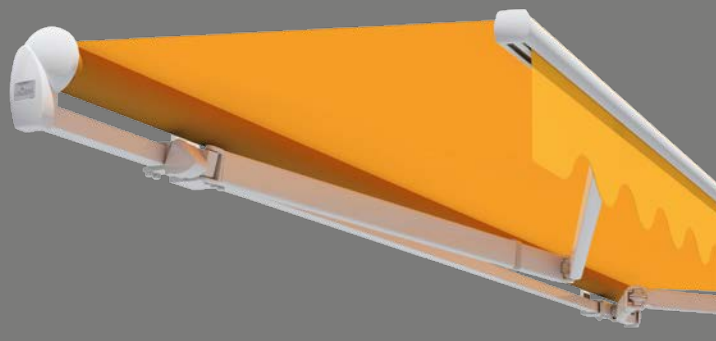

Typen [Types]

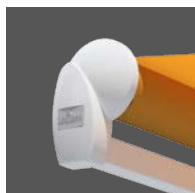

Offen
Open



Regendach
Rain cover

Ausstattung [Specification]	
Ausfallprofil [Front profile]	„eckig“ [“square”]
Volant [Valance]	■
Tuchabdeckschale [Fabric cover shell]	—
Breite 1-teilig [Width 1 unit]	max. 600 cm
Ausfall [Drop]	max. 300 cm
Antrieb [Drive]	Kurbel [crank] ■ Motor □

■ Standard □ Option — nicht erhältlich [not available]

Optionen [Options]



LED-Spotleiste
LED spot bar

- Funkmotor [Radio motor]
- Wetterautomatik [Automatic weather monitoring]
- Heizstrahler [Patio heater]
- Stützbeine [Support legs]



Gelenkarmmarkise (Tragrohr)
Folding arm awning (back bar)

Family Classic

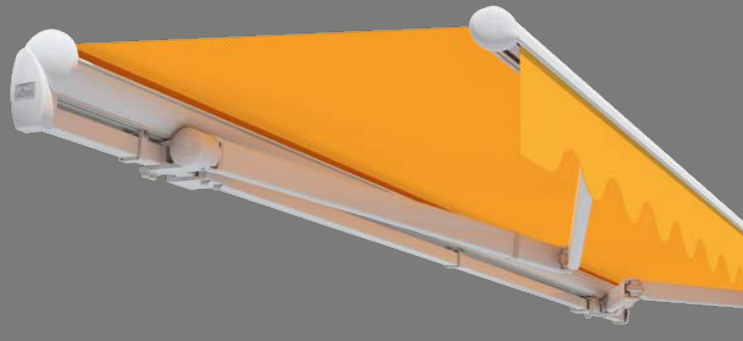

Typen [Types]



Offen
Open



Regendach
Rain cover



Hülse
Encased

Ausstattung [Specification]	
Ausfallprofil [Front profile]	„oval“
Volant [Valance]	■
Tuchabdeckschale [Fabric cover shell]	■
Breite 1-teilig [Width 1 unit]	max. 700 cm
Koppelanlage [Joined system]	max. 1950 cm
Ausfall [Drop]	max. 400 cm
Antrieb [Drive]	Kurbel [crank] □ Motor ■

■ Standard □ Option

Optionen, für alle Typen [Options for all types]

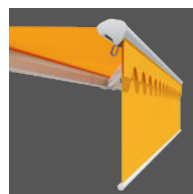

Vario Volant
Vario Valance

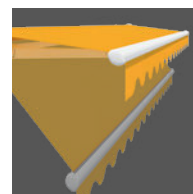

Lewens-Matik
Lewens-Matik

- Funkmotor [Radio motor]
- Wetterautomatik [Automatic weather monitoring]
- LED-Spotleiste [LED spot bar]
- Heizstrahler [Patio heater]
- Stützbeine [Support legs]



Family Design

Family Compact

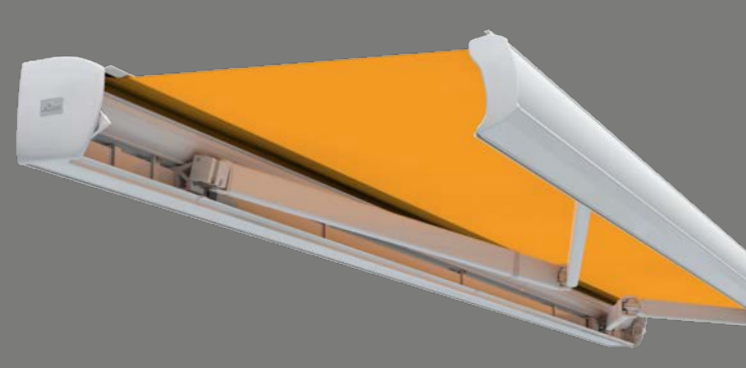

Typen [Types]



Offen
Open



Regendach
Rain cover



Hülse
Encased

Typen [Types]



Halbkassette
3-seitig geschlossen
Semi-cassette, closed on 3 sides



Kassette
4-seitig geschlossen
Cassette, closed on 4 sides

Ausstattung [Specification]

Ausfallprofil „Design“ [“Designer” front profile]		
Volant [Valance]		<input type="checkbox"/>
Volant für XXL [Valance for XXL]		<input checked="" type="checkbox"/>
Tuchabdeckschale [Fabric cover shell]		<input checked="" type="checkbox"/>
Breite 1-teilig [Width 1 unit]	max. 700 cm	
Koppelanlage [Joined system]	max. 1950 cm	
Ausfall [Drop]	max. 400 cm	
Antrieb [Drive]	Kurbel [crank] <input type="checkbox"/> Motor <input checked="" type="checkbox"/>	

Standard Option

Ausstattung [Specification]

Gehäuse [Casing]	kompakter Abschluss [compact casing]	
Volant [Valance]		<input type="checkbox"/>
Tuchabdeckschale [Fabric cover shell]		<input checked="" type="checkbox"/>
Breite 1-teilig [Width 1 unit]		max. 650 cm
Koppelanlage [Joined system]		max. 1950 cm
Ausfall [Drop]		max. 350 cm
Antrieb [Drive]	Kurbel [crank] <input type="checkbox"/> Motor <input checked="" type="checkbox"/>	

Standard Option

Optionen [Options]

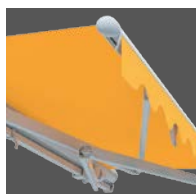

XXL-Arme
XXL arms



LED-Spotleiste
LED spot bar

- **Funkmotor** [Radio motor]
- **Wetterautomatik** [Automatic weather monitoring]
- **Heizstrahler** [Patio heater]
- **Stützbeine** [Support legs]



LED-Spotleiste
LED spot bar

- **Funkmotor** [Radio motor]
- **Wetterautomatik** [Automatic weather monitoring]
- **Heizstrahler** [Patio heater]
- **Stützbeine** [Support legs]



Gelenkarmmarkise (Vollkassette)
Folding arm awning [full cassette]

Trentino Mini

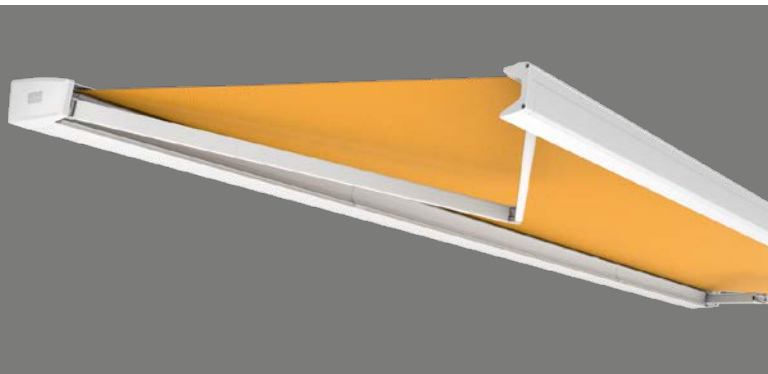

Typen [Types]



Eckig
Angular

Ausstattung [Specification]

Mini-Flachkassette [Flat mini-cassette]	
Wandbündige Kassette [Cassette, flush to the wall]	
Tuchabdeckschale [Fabric cover shell]	■
Breite 1-teilig [Width 1 unit]	max. 450 cm
Ausfall [Drop]	max. 250 cm
Antrieb [Drive]	Kurbel [crank] <input type="checkbox"/> Motor <input checked="" type="checkbox"/>

■ Standard Option

Optionen [Options]

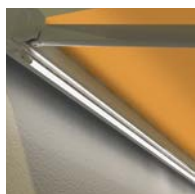

LED-Lichtleiste
LED lighting strip

- Funkmotor [Radio motor]
- Wetterautomatik [Automatic weather monitoring]
- Stützbeine [Support legs]



Gelenkarmmarkise (Vollkassette)
Folding arm awning [full cassette]

Trentino

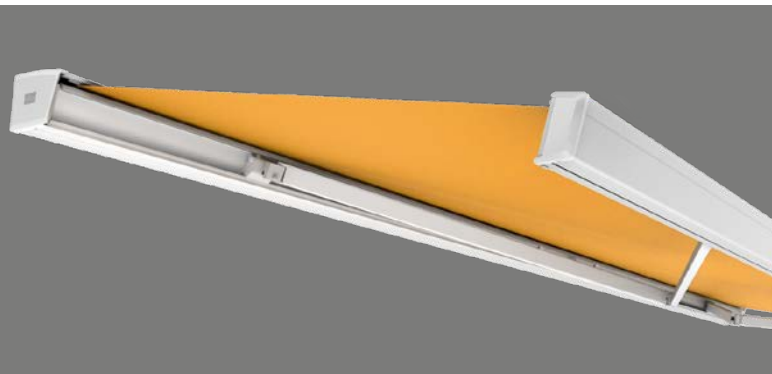

Typen [Types]



Eckig
Angular



Rund
Rounded

Ausstattung [Specification]

Flachkassette, wandbündig [Flat cassette, flush to the wall]	
Volant [Valance]	<input type="checkbox"/>
Tuchabdeckschale [Fabric cover shell]	■
Breite 1-teilig [Width 1 unit]	max. 700 cm
Koppelanlage [Joined system]	max. 1950 cm
Ausfall [Drop]	max. 400 cm
Antrieb [Drive]	Kurbel [crank] <input type="checkbox"/> Motor <input checked="" type="checkbox"/>

■ Standard Option

Optionen [Options]



Vario Volant
Vario Valance



LED-Spotleiste
LED spot bar

- Funkmotor [Radio motor]
- Wetterautomatik [Automatic weather monitoring]
- Heizstrahler [Patio heater]
- Stützbeine [Support legs]



Toscana Mini

Toscana

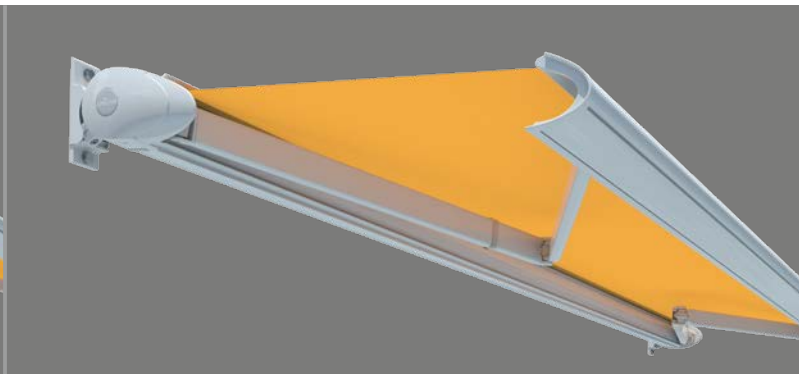
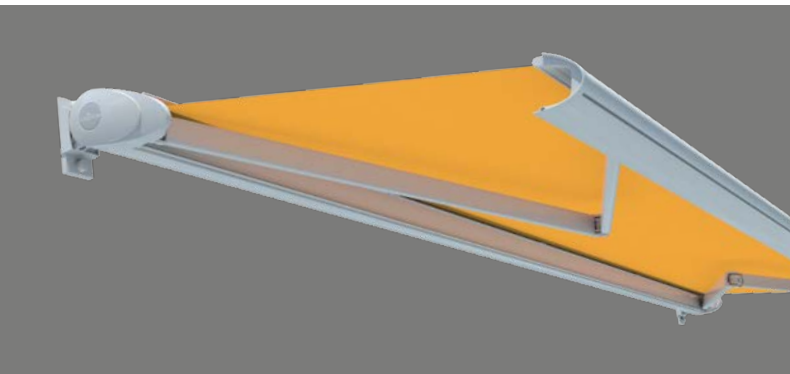

Typen [Types]



Typen [Types]



Ausstattung [Specification]

Mini-Kassette [Mini-cassette]

Volant [Valance]

Tuchabdeckschale [Fabric cover shell]

Breite 1-teilig [Width 1 unit] max. 450 cm

Ausfall [Drop] max. 250 cm

Antrieb [Drive] Kurbel [crank] Motor

■ Standard Option

Ausstattung [Specification]

Kleine Kassette [Small cassette]

Volant [Valance]

Tuchabdeckschale [Fabric cover shell]

Breite 1-teilig [Width 1 unit] max. 550 cm

Ausfall [Drop] max. 300 cm

Antrieb [Drive] Kurbel [crank] Motor

■ Standard Option

Optionen [Options]

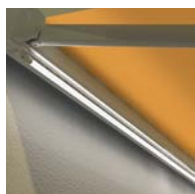

- Funkmotor [Radio motor]
- Wetterautomatik [Automatic weather monitoring]
- Stützbeine [Support legs]

LED-Lichtleiste
LED lighting strip

Optionen [Options]

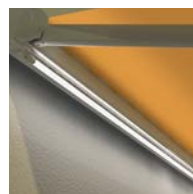

- Funkmotor [Radio motor]
- Wetterautomatik [Automatic weather monitoring]
- Stützbeine [Support legs]

LED-Lichtleiste
LED lighting strip



Gelenkarmmarkise (Vollkassette)
Folding arm awning [full cassette]

Toscana Grande

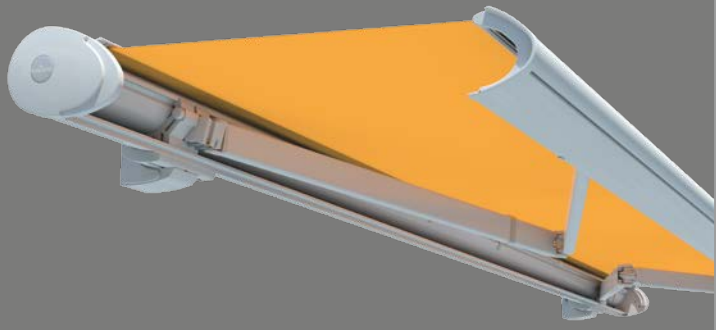

Typen [Types]



Ausstattung [Specification]

Große Kassette [Large cassette]	
Volant [Valance]	<input type="checkbox"/>
Tuchabdeckschale [Fabric cover shell]	<input checked="" type="checkbox"/>
Breite 1-teilig [Width 1 unit]	max. 700 cm
Koppelanlage [Joined system]	max. 1950 cm
Ausfall [Drop]	max. 400 cm
Antrieb [Drive]	Kurbel [crank] <input type="checkbox"/> Motor <input checked="" type="checkbox"/>

■ Standard □ Option

Optionen [Options]



Vario Volant
Vario Valance



LED-Spotleiste
LED spot bar

- Funkmotor [Radio motor]
- Wetterautomatik [Automatic weather monitoring]
- Heizstrahler [Patio heater]
- Stützbeine [Support legs]

Option

Vario Volant [Vario Valance]

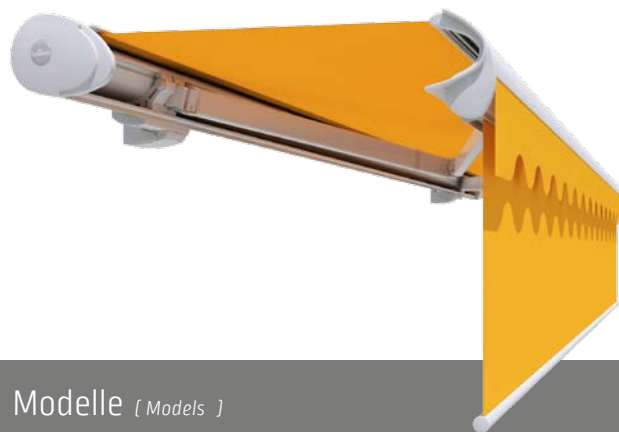

Modelle [Models]

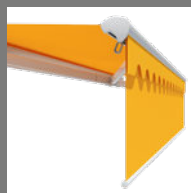

Family Classic



Trentino Eckig
Trentino Angular

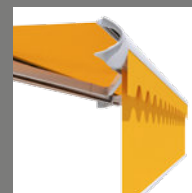

Toscana Grande



Ancona Unterglas
Ancona Roof-mounted

Der Vario Volant bietet einen variablen Sonnen- und Sichtschutz, wobei die Durchgangshöhe unter der Markise erhalten bleibt.

The Vario Valance offers variable shade from the sun and privacy while retaining the headroom below the awning.

Ausstattung [Specification]

Antrieb [Drive]	Kurbel [crank] <input checked="" type="checkbox"/>
	Funkmotor [radio control motor] * <input type="checkbox"/>
Acrylstoff [Acrylic fabric]	<input checked="" type="checkbox"/>
+ Kurbel [crank]	Höhe [Height] 150 / 200 cm
+ Motor	Höhe [Height] 150 cm
Soltis 92	<input type="checkbox"/>
	Höhe ca. [Height approx.] 160 cm

■ Standard □ Option * nicht Ancona [not Ancona]



Ancona

Capri

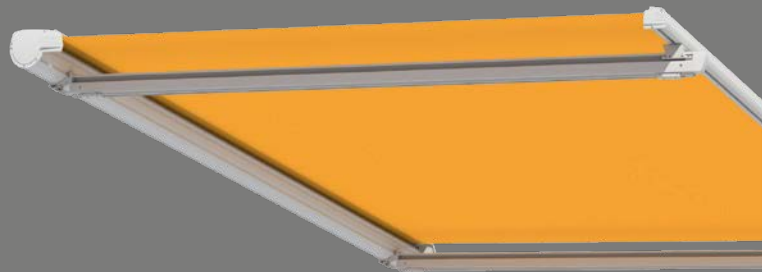
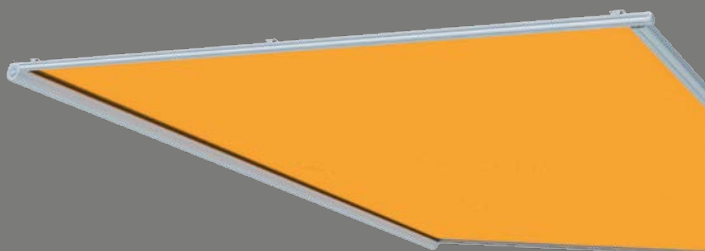

Typen [Types]



Unterglas
Interior



Aufglas (inkl. Dachabdeckung)
Roof-mounted (incl. top cover)

Typen [Types]



Dachmontage
Roof-mounted



Pergola

Ausstattung [Specification]

Kassette [Cassette]

- für Wintergarten/Glasdach [for conservatory/glass roof]
- Unter- oder Aufglasmontage [Interior or roof-mounted]

Breite 1-teilig [Width 1 unit] max. 600 cm

Ausfall [Drop] max. 450 cm

Antrieb [Drive] Motor ■

■ Standard

Ausstattung [Specification]

Kassette [Cassette]

- für Wintergarten/Glasdach [for conservatory/glass roof]
- als Pergola freitragend [self-supporting as Pergola type]

Dachmontage [For roof-mounting]

Breite 1-teilig [Width 1 unit] max. 700 cm

Koppelanlage [Joined system] max. 1200 cm

Ausfall [Drop] max. 600 cm

Pergola

Breite 1-teilig [Width 1 unit] max. 600 cm

Ausfall [Drop] max. 600 cm

Antrieb [Drive] Motor ■

■ Standard

Optionen [Options]



Vario Volant
Vario Valance

- Funkmotor [Radio motor]
- Wetterautomatik [Automatic weather monitoring]
- Tuchstützdraht [Fabric support wire]
- Typ Unterglas: Dachabdeckung [Interior type: top cover]

Optionen [Options]

- Funkmotor [Radio motor]
- Wetterautomatik [Automatic weather monitoring]
- Extra-Tuchstütze [Extra fabric support]



Micro 100



Typen [Types]



Tuchneigung 90°
Awning pitch 90°

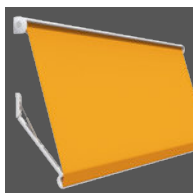

Tuchneigung 135°
Awning pitch 135°

Ausstattung [Specification]

Fallarmmarkise [Drop-arm awning]

Wandbündige Kassette [Cassette flush with wall]

Breite 1-teilig [Width 1 unit] max. 700 cm

Ausfall [Drop] max. 175 cm

Antrieb [Drive] Kurbel [crank] Motor

■ Standard Option

Optionen [Options]

- **Funkmotor**
[Radio motor]
- **Wetterautomatik**
[Automatic weather monitoring]



Micro 150

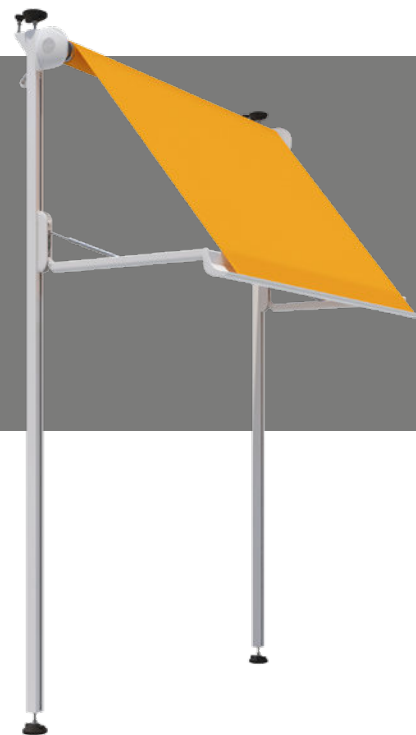

Typen [Types]

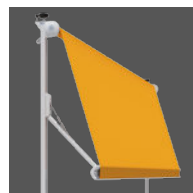

Tuchneigung 135°
Awning pitch 135°

Ausstattung [Specification]

Fallarmmarkise [Drop-arm awning]

Klemmpfosten, Decke – Boden [Clamping posts, ceiling – floor]

Breite 1-teilig [Width 1 unit] max. 350 cm

Höhe inkl. Pfosten [Height incl. posts] max. 300 cm

Ausfall [Drop] max. 125 cm

Antrieb [Drive] Motor Kurbel [crank]

■ Standard Option

Optionen [Options]

- **Funkmotor**
[Radio motor]
- **Wetterautomatik**
[Automatic weather monitoring]



Micro 200

Micro 300

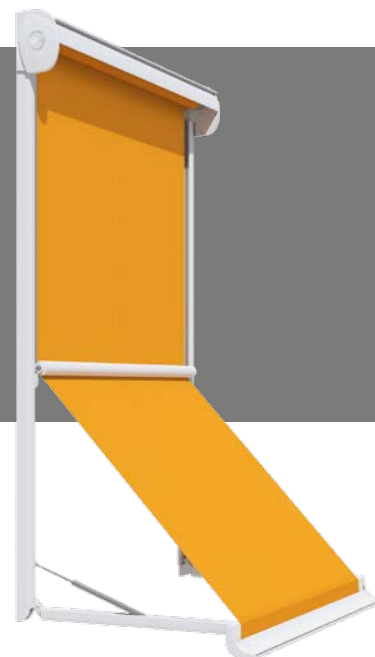
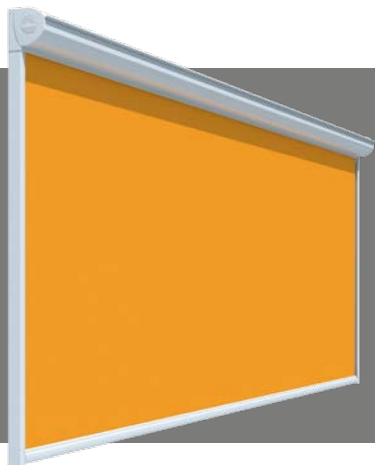

Typen [Types]



Schienerführung
Track guide

Seilführung
Cable guide

Typen [Types]

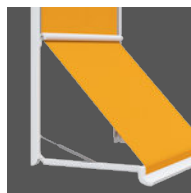

Tuchneigung 135°
Awning pitch 135°

Ausstattung [Specification]

Senkrechtmarkise [Vertical awning]

Wandbündige Kassette [Cassette flush with wall]

Schienerführung [Track guide]

Breite 1-teilig [Width 1 unit] max. 400 cm

Höhe [Height] max. 300 cm

Seilführung [Cable guide]

Breite 1-teilig [Width 1 unit] max. 400 cm

Höhe [Height] max. 275 cm

Antrieb [Drive] Kurbel [crank] Motor

Standard Option

Optionen [Options]

- **Funkmotor**
[Radio motor]
- **Wetterautomatik**
[Automatic weather monitoring]



Ausstattung [Specification]

Markisolette

Wandbündige Kassette [Cassette flush with wall]

Breite 1-teilig [Width 1 unit] max. 350 cm

Höhe [Height] max. 275 cm

Armlänge [Arm length] immer [always] 72,5 cm

Antrieb [Drive] Kurbel [crank] Motor

Standard Option

Optionen [Options]

- **Funkmotor**
[Radio motor]
- **Wetterautomatik**
[Automatic weather monitoring]



Micro 700

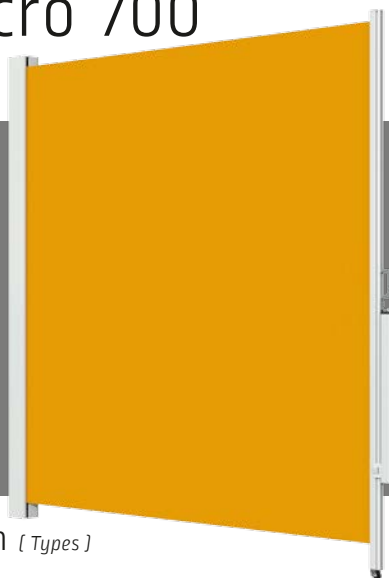

Typen [Types]



Ausstattung [Specification]

Seitenzug-Markise [Side screen awning]

Wandseitige Kassette [Cassette on wall side]

Anlagenhöhe [Unit height] bis (up to) max. 250 cm

Auszug, abhängig von Höhe und Stoff [Extension depending on height and fabric] max. 400 cm

Befestigung [Attachment]

Wandhalterung [Wall mounting bracket]

Pfosten [Posts]

Antrieb [Drive] Handbetrieb [manual operation]

Standard Option

Micro 850 (Z)/1000 (Z)

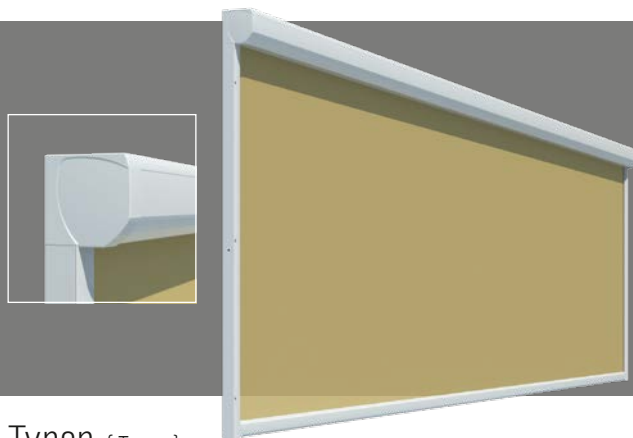

Typen [Types]

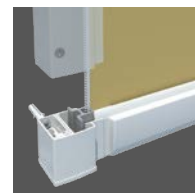
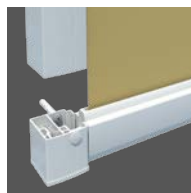

Führung offen

Schiene ohne Tuchführung
Open guide
Track without fabric guide

Führung geschlossen (Z)

Schiene mit Tuchführung
Closed guide (Z),
Track with fabric guide

Ausstattung [Specification]

Senkrechtmarkise [Vertical awning]

Kassette wandbündig [Cassette flush with wall]

Bespannung [Fabric] Screen, Soltis *

Antrieb [Drive] Kurbel [crank] Motor

Führung offen + Motor

[Open guide + motor drive]	Micro	850	1000
Breite 1-teilig [Width 1 unit] max.		300 cm	400 cm
Koppelanlage [Joined system] max.		–	800 cm
Höhe [Height] max.		250 cm	375 cm

Führung geschlossen (Z) + Motor

[Closed guide Z + motor drive]	Micro	850 Z	1000 Z
Breite 1-teilig [Width 1 unit]		275 cm	400 cm
Koppelanlage [Joined system] max.		–	800 cm
Höhe [Height]		175 cm	350 cm

Standard Option * nur Führung offen (only open guide type)

Optionen [Options]

- Funkmotor [Radio motor]
- Wetterautomatik [Automatic weather monitoring]



Micro 860 (Z) /1060 (Z)

Micro 4000 Z

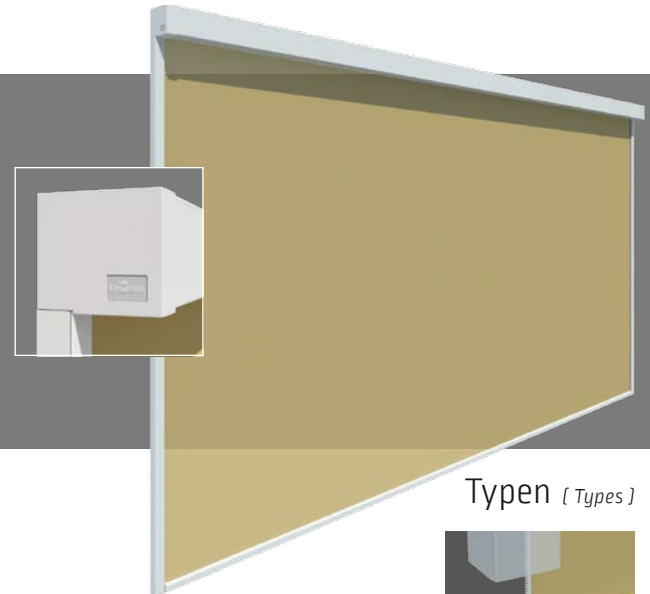
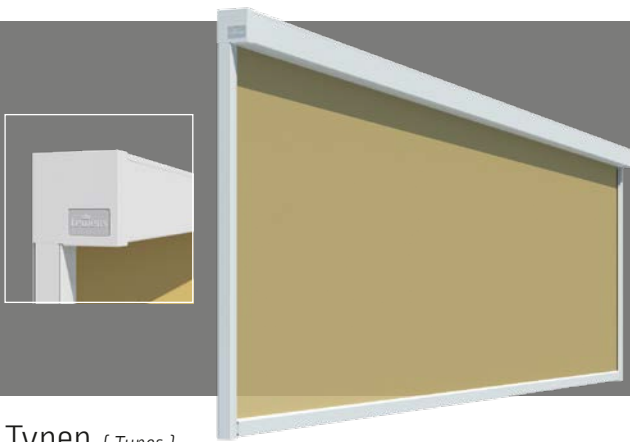

Typen [Types]

Typen [Types]

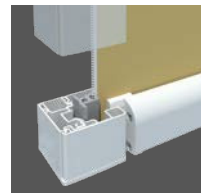
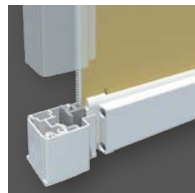
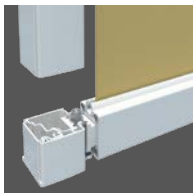

Führung offen

Schiene ohne Tuchführung
Open guide
Track without fabric guide

Führung geschlossen (Z)

Schiene mit Tuchführung
Closed guide (Z),
Track with fabric guide

Führung geschlossen (Z)

Closed guide (Z)

Ausstattung [Specification]

Senkrechtmarkise [Vertical awning]

Kassette wandbündig, **eckig** [Square cassette flush with wall]

Bespannung [Fabric] Screen, Soltis *

Antrieb [Drive] Kurbel [crank] Motor

Führung offen + Motor

[Open guide + motor drive] **Micro 860 1060**

Breite 1-teilig [Width 1 unit] max. 300 cm 400 cm

Höhe [Height] max. 250 cm 375 cm

Führung geschlossen (Z) + Motor

[Closed guide Z + motor drive] **Micro 860 Z 1060 Z**

Breite 1-teilig [Width 1 unit] 275 cm 400 cm

Höhe [Height] 175 cm 350 cm

Standard Option * nur Führung offen [only open guide type]

Ausstattung [Specification]

Senkrechtmarkise [Vertical awning]

für große einteilige Flächen [for large single units]

Kassette wandbündig, **eckig** [Square cassette flush with wall]

Bespannung [Fabric]

Screen

Fenstertücher [Window awnings]

Antrieb [Drive] Motor

Breite 1-teilig [Width 1 unit] max. 550 cm

Höhe [Height] max. 600 cm

Standard Option

Optionen [Options]

- Funkmotor [Radio motor]
- Wetterautomatik [Automatic weather monitoring]



Optionen [Options]

- Funkmotor [Radio motor]
- Wetterautomatik [Automatic weather monitoring]



Murano Vetro Typ B

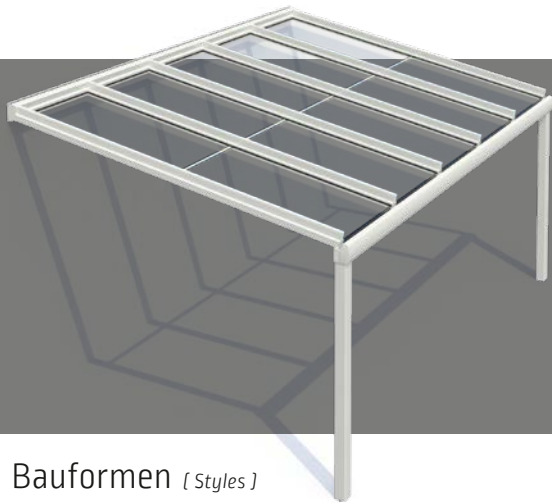

Bauformen [Styles]



B1 bündig,
außen
*Flush,
posts on outside*

B2 bündig,
eingerrückt
*Flush,
posts recessed*

B3 wie B1,
mit 3. Stütze
*as B1,
with 3rd support*

Ausstattung [Specification]

Glasdach als Wetterschutz für Terrassen
[Glass roof as protection from the weather for your patio]

Breite [Width] max. 700 cm

Tiefe [Drop] max. 500 cm

Neigungswinkel [Pitch] 3° - 20

• **traufständige Pfosten** für maximal nutzbaren Raum
[Posts in line with the front profile for maximum space utilisation]

• Regenrinne in einer Linie mit den Pfosten
[Rain gutter in line with the posts]

• Regenableitung über Sparren, Regenrinne, Pfosten
[Rainwater drains via purlins, rain gutter and inside of posts]

mit integriertem Fallrohr *[with integral downpipe]*

für Verglasung mit Verbundsicherheitsglas (VSG, klar)
[must be constructed with laminated safety glass: LSG, clear]

Standard nicht im Lieferumfang enthalten *[not included]*

Optionen [Options]

- Glaswände *[Glass walls]*
- LED-Beleuchtung *[LED lighting]*
- Heizstrahler *[Patio heating]*



Typ B1
[Type B1]

Murano Vetro Typ Ü

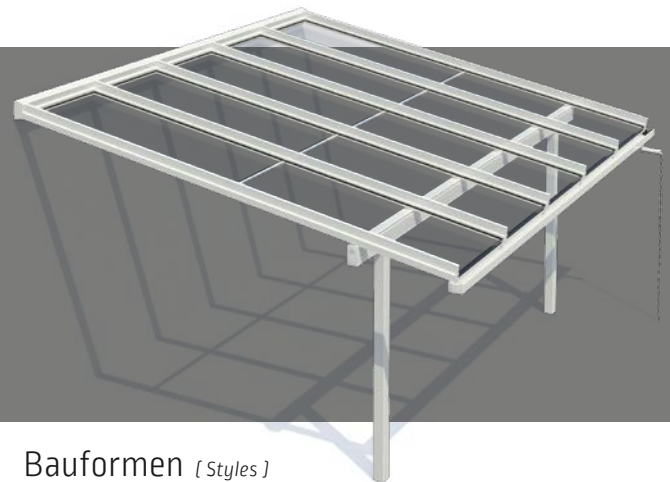

Bauformen [Styles]



Ü1 Sparrenüber-
stand, außen
*Purlin overhang,
posts on outside*

Ü2 Sparrenüberst.,
eingerrückt
*Purlin overhang,
posts recessed*

Ü3 wie Ü1,
mit 3. Stütze
*as Ü1,
with 3rd support*

Ausstattung [Specification]

Glasdach als Wetterschutz für Terrassen
[Glass roof as protection from the weather for your patio]

Breite [Width] max. 700 cm

Tiefe [Drop] max. 500 cm

Neigungswinkel [Pitch] 3° - 20

• mit **Dachüberstand** über Pfosten und Pfette hinaus
[Roof overhang taken out beyond posts and cross-member]

• Regenableitung z.B. über Kette
[Rainwater drainage e.g. via a chain]

Lieferung inkl. 1 St. Regenkette und Wasserspeier
[supplied including 1 rain chain and water spout]

für Verglasung mit Verbundsicherheitsglas (VSG, klar)
[must be constructed with laminated safety glass: LSG, clear]

Standard nicht im Lieferumfang enthalten *[not included]*

Optionen [Options]

- Glaswände *[Glass walls]*
- LED-Beleuchtung *[LED lighting]*
- Heizstrahler *[Patio heating]*



Typ Ü2
[Type Ü2]

Murano Integrale Typ B

Murano Integrale Typ Ü

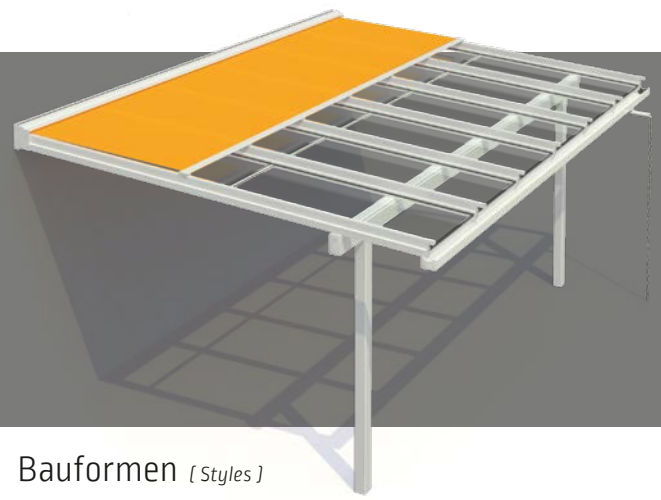
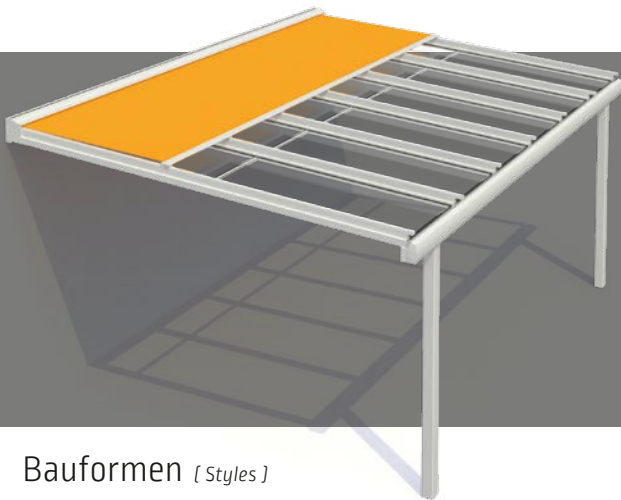

Bauformen [Styles]

Bauformen [Styles]



B1 bündig,
außen
*Flush,
posts on outside*

B2 bündig,
eingerrückt
*Flush,
posts recessed*

B3 wie B1,
mit 3. Stütze
*as B1,
with 3rd support*

Ü1 Sparrenüber-
stand, außen
*Purlin overhang,
posts on outside*

Ü2 Sparrenüberst.,
eingerrückt
*Purlin overhang,
posts recessed*

Ü3 wie Ü1,
mit 3. Stütze
*as Ü1,
with 3rd support*

Ausstattung [Specification]

Glasdach mit in das Wandprofil integrierter Markise
[Glass roof with awning integrated into wall profile]

Breite [Width] max. 700 cm

Tiefe [Drop] max. 500 cm

Neigungswinkel [Pitch] 3° - 20

• **traufständige Pfosten** für maximal nutzbaren Raum
[Posts in line with the front profile for maximum space utilisation]

• Regenrinne in einer Linie mit den Pfosten
[Rain gutter in line with the posts]

• Regenableitung über Sparren, Regenrinne, Pfosten
[Rainwater drains via purlins, rain gutter and inside of posts]

mit integriertem Fallrohr *[with integral downpipe]*

für Verglasung mit Verbundsicherheitsglas (VSG, klar)
[must be constructed with laminated safety glass: LSG, clear]

Standard nicht im Lieferumfang enthalten *[not included]*

Optionen [Options]

- Glaswände *[Glass walls]*
- Funkmotor *[Radio motor]*
- LED-Beleuchtung *[LED lighting]*
- Wetterautomatik *[Automatic weather monitoring]*
- Heizstrahler *[Patio heating]*



Typ B2
[Type B2]

Ausstattung [Specification]

Glasdach mit in das Wandprofil integrierter Markise
[Glass roof with awning integrated into wall profile]

Breite [Width] max. 700 cm

Tiefe [Drop] max. 500 cm

Neigungswinkel [Pitch] 3° - 20

• mit **Dachüberstand** über Pfosten und Pfette hinaus
[Roof overhang taken out beyond posts and cross-member]

• Regenableitung z.B. über Kette
[Rainwater drainage e.g. via a chain]

Lieferung inkl. 1 St. Regenkette und Wasserspeier
[supplied including 1 rain chain and water spout]

für Verglasung mit Verbundsicherheitsglas (VSG, klar)
[must be constructed with laminated safety glass: LSG, clear]

Standard nicht im Lieferumfang enthalten *[not included]*

Optionen [Options]

- Glaswände *[Glass walls]*
- Funkmotor *[Radio motor]*
- LED-Beleuchtung *[LED lighting]*
- Wetterautomatik *[Automatic weather monitoring]*
- Heizstrahler *[Patio heating]*



Typ Ü1
[Type Ü1]

Murano Puro Typ B

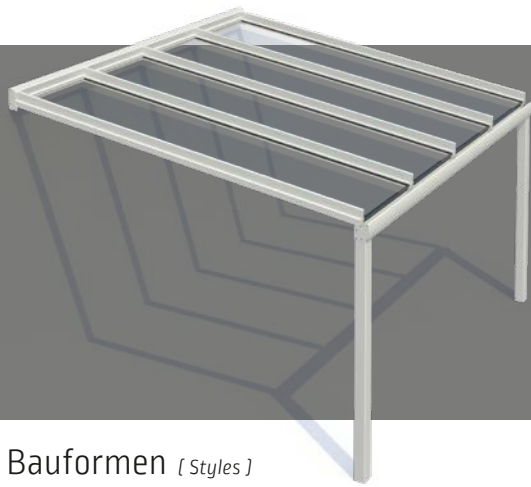

Bauformen [Styles]



B1 bündig, außen
Flush, posts on outside

B2 bündig, eingerückt
Flush, posts recessed

B3 wie B1, mit 3. Stütze
as B1, with 3rd support

Ausstattung [Specification]

Einsteigermodell für kleine bis mittlere Flächen
[Entry-level model for small to medium-sized patios]

Breite [Width] max. 700 cm

Tiefe [Drop] max. 350 cm

Neigungswinkel [Pitch] 3° - 10°

• **traufständige Pfosten** für maximal nutzbaren Raum
[Posts in line with the front profile for maximum space utilisation]

• Regenrinne in einer Linie mit den Pfosten
[Rain gutter in line with the posts]

• Regenableitung über Sparren, Regenrinne, Pfosten
[Rainwater drains via purlins, rain gutter and inside of posts]

mit integriertem Fallrohr [with integral downpipe]

für Verglasung mit Verbundsicherheitsglas (VSG, klar)
[must be constructed with laminated safety glass: LSG, clear]

Standard nicht im Lieferumfang enthalten [not included]

Optionen [Options]

- Glaswände [Glass walls]
- LED-Beleuchtung [LED lighting]
- Heizstrahler [Patio heating]



Typ B1
[Type B1]

Murano Glissando

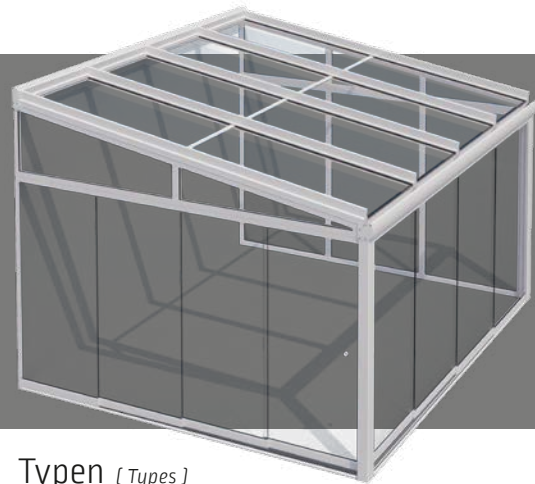

Typen [Types]

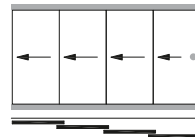

Seiten-öffnend
(rechts oder links)
2-, 3-, 4- oder 5-spurig

Side opening [right or left]
2-, 3-, 4- or 5-track

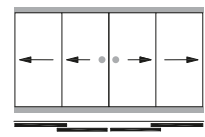

Mittig öffnend
2-, 3-, 4- oder 5-spurig

Central opening
2-, 3-, 4- or 5-track

Ausstattung [Specification]

Wände aus **verschiebbaren Glasflächen**
[Walls comprising sliding glass panels]

für Seiten (mit Quertraverse/Dreieckschluss) / Front
[for sides – with cross member/triangular infill – /front]

Breite [Width] max. 1150 cm

Höhe [Height] max. 260 cm

Breite Einzelement [Width, individual elements] 60 - 130 cm

Lieferung inkl. Glas [Delivery incl. glass]

Lieferung ohne Glas [Delivery without glass]

Verglasung mit Einscheibensicherheitsglas (ESG, klar)
[walls must be fitted with single-pane safety glass – SPSG, clear]

Standard Option

Optionen [Options]

- **Schloss** – in Griffhöhe
[Lock – at handle height]
- **Quertraverse** – zur Verwendung als Seitenwand
[cross member – for use as side wall]
- **Profile bzw. Haltetaschen für Dreieckschluss**
[retaining strips or retainer clips for triangular infill]



Murano Finestra

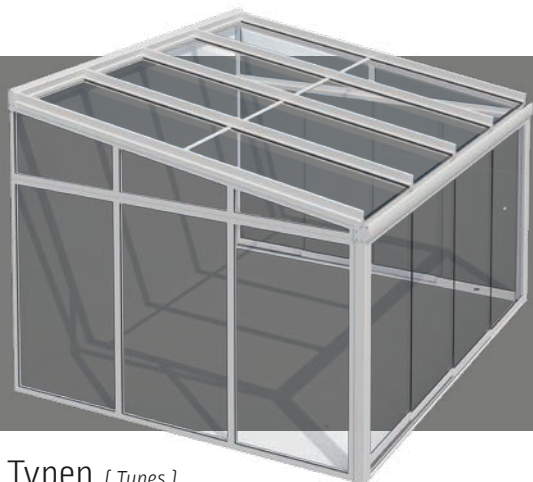

Typen [Types]

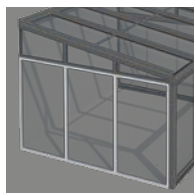

Rechteck
Rectangle

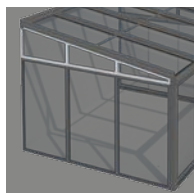

Schräg-Element
Inclined section

Ausstattung [Specification]

Feste Teilverglasung oder Komplettverglasung

[Partial permanent glazing or complete permanent glazing]

mit Vertikalsprossen [With uprights]

Anzahl Vertikalsprossen Breitenabhängig
[Number of uprights] [Width-dependent]

für Seiten / Front / Rückseite – ggf. mit Tragrahmen
[for sides / front / back – with support frame if applicable]

Breite [Width] max. 500 cm

Höhe [Height] max. 230 cm

Breite Einzelelement [Width, individual elements] 120 cm

Lieferung ohne Glas [Delivery without glass]

Verglasung mit Einscheibensicherheitsglas (ESG, klar)
[walls must be fitted with single-pane safety glass – SPSG, clear]

Standard Option

Optionen [Options]

- Extra Vertikalsprosse [extra upright]
- diverse Verbindungs-, Anschluss- und Abschlussprofile [various connection and finishing profiles]



Elektrik [Electrics]

Möchten Sie mehr Komfort?

Dann stehen Ihnen Funksteuerungen, Beleuchtung, Heizstrahler und Wetter-Automatik im Somfy-io-Standard zur Verfügung, so dass diese in die Hausautomation eingebunden werden können: Bedienkomfort per Tablet oder Smartphone!

Would you like greater convenience?

Then you have the choice of radio remote controls, lighting, radiant heaters and automatic weather sensing components in Somfy-io-standard that can be integrated into home automation systems: Operating convenience via tablet or smartphone!

Funksteuerungen in io-Technik von Somfy schaffen die Voraussetzung dafür, alle Terrassenfunktionen in die Hausautomation (TaHoma, Connexoon) einzubinden, mit Bedienkomfort per Tablet oder Smartphone.

Radio controls in io-technology from Somfy create the conditions for integrating all patio functions into home automation systems (TaHoma, Connexoon), with operating convenience via tablet or smartphone.



Wetter-Automatik

im io-Standard sorgt für wetterabhängige automatische Steuerung von Markisen.

Automatic weather sensors in io-standard ensure automatic control of the awning dependent on the weather conditions.



LED-Beleuchtung

Ausgestattet mit einem Funkempfänger für io-Technik lässt sich immer die passende Lichtstimmung für jede Situation zaubern.

LED lighting

With a radio receiver for io-technology, suitable mood lighting for any situation can be conjured up.

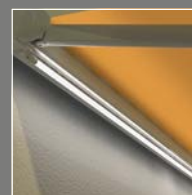

Infrarot-Heizstrahler

im io-Standard schaffen auch an kühlen Tagen Behaglichkeit und wohlige Wärme unter Markisen und Glasdächern.

Infrared radiant heaters to io standard create a cosy atmosphere and pleasant warmth under awnings and glass roofs, even on chilly days.

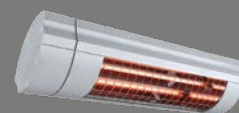



www.lewens-markisen.de

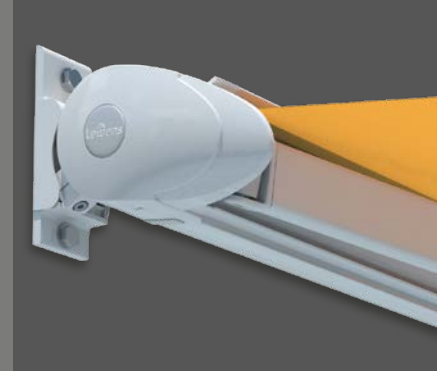

Ihr Fachhändler berät Sie gern:
Your stockist will be happy to advise you:

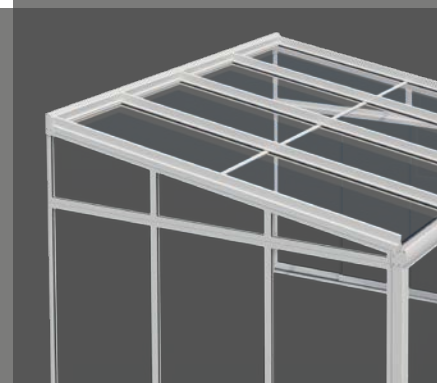
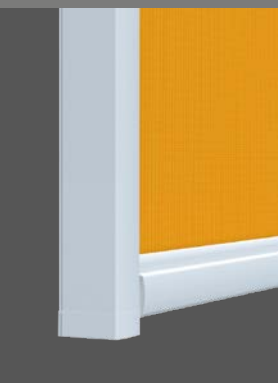

Technische Änderungen vorbehalten. Stand 03/2019
Subject to technical alterations. Date: 03/2019